

LF120 (-S) US / LF230 (-S) US

On-off, spring return failsafe, 120/230 VAC



Torque min. 35 in-lb, for control of air dampers

Application

For on-off, fail-safe control of dampers in HVAC systems. Actuator sizing should be done in accordance with the damper manufacturer's specifications. Control is on-off from an auxiliary contact, or a manual switch.

The actuator is mounted directly to a damper shaft from 3/8" up to 1/2" in diameter by means of its universal clamp, 1/2" shaft centered at delivery. For shafts up to 3/4" use K6-1 accessory. A crank arm and several mounting brackets are available for applications where the actuator cannot be direct coupled to the damper shaft.

Operation

The LF series actuators provide true spring return operation for reliable fail-safe application and positive close off on air tight dampers. The spring return system provides consistent torque to the damper with, and without, power applied to the actuator. The LF series provides 95° of rotation and is provided with a graduated position indicator showing 0° to 95°. The actuator may be stalled anywhere in its normal rotation without the need of mechanical end switches. Power consumption is reduced in holding mode. The actuator is double insulated so an electrical ground connection is not necessary.

The LF120-S US and LF230-S US versions are provided with 1 built-in auxiliary switch. This SPDT switch is provided for safety interfacing or signaling, for example, for fan start-up. The switching function is adjustable between 0° and 95°.

Technical Data	LF120 (-S) US	LF230 (-S) US
Power supply	120 VAC ± 10% 50/60 Hz	230 VAC ± 10% 50/60 Hz
Power consumption	running: 5.5 W holding: 3.5 W	5 W 3 W
Transformer sizing	7.5 VA	7 VA
Electrical connection	3 ft, 18 GA appliance cable (-S models have 2 cables) 1/2" conduit connector	
Overload protection	electronic throughout 0 to 95° rotation	
Electrical protection	actuators are double insulated	
Angle of rotation	max 95°, adjust. with mechanical stop	
Torque	35 in-lb [4 Nm] constant torque	
Direction of rotation	reversible with cw/ccw mounting	
Position indication	visual indicator, 0° to 95° (0° is spring return position)	
Auxiliary switch (-S models)	1 x SPDT 6A (1.5A) @ 250 VAC, UL listed adjustable 0° to 95°	
Electrical protection	actuators are double insulated	
Running time (nominal)	motor: < 40 to 75 sec spring: < 25 sec @ -4°F to +122°F [-20°C to +50°C] < 60 sec @ -22°F [-30°C]	
Humidity	5 to 95% RH non-condensing	
Ambient temperature	-22°F to +122°F [-30°C to +50°C]	
Storage temperature	-40°F to +176°F [-40°C to +80°C]	
Housing	NEMA type 2 / IP54	
Housing material	zinc coated steel	
Agency listings	UL 873, CSA C22.2 No. 24 Certified, CE [LF230(-S) US]	
Noise level	max: running < 50 db (A) spring return 62 dB (A)	
Servicing	maintenance free	
Quality standard	ISO 9001	
Weight	LF120/230	3.4 lbs (1.54 kg.) LF120/230-S 3.5 lbs (1.60 kg.)

Dimensions [All numbers in brackets are in millimeters.]

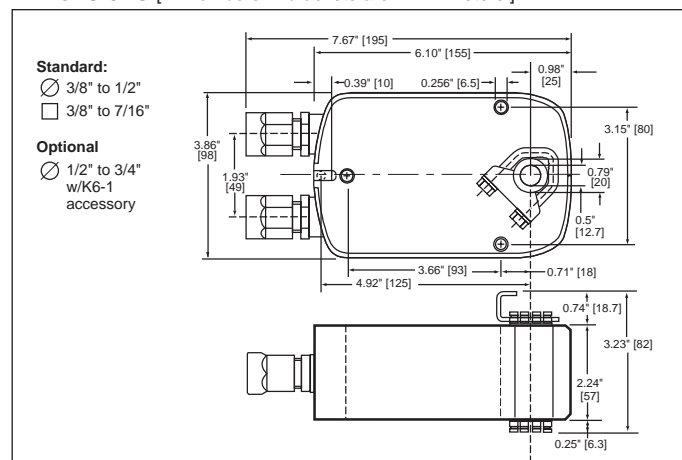

G20492-IG-Subject to change. © Belimo Aircontrols (USA), Inc.

Accessories

AV 10-18	Shaft extension (K6-1 is required)
IND-LF	Damper position indicator
K6-1	Universal clamp for up to 3/4" diameter shafts
KH-LF	Crankarm for up to 1/2" round shaft
Tool-06	8mm and 10 mm wrench
ZG-LF2	Crankarm adaptor kit for LF
ZG-112	Mounting bracket for Honeywell Mod IV, M6415 type actuators, and new installations
ZG-LF112	Crankarm adaptor kit for Honeywell Mod IV, M6415 type actuators, and new installations
ZS-100	Weather shield (metal)
ZS-150	Weather shield (polycarbonate)
ZS-260	Explosion-proof housing

Note: When using LF120/230 US and LF120-S/230-S US actuators, only use accessories listed on this page.

LF120 (-S) US / LF230 (-S) US Typical Specification

On-off spring return damper actuators shall be direct coupled type which require no crankarm and linkage and be capable of direct mounting to a shaft up to a 3/4" diameter and center a 1/2" shaft. The actuators must be designed so that they may be used for either clockwise or counterclockwise fail-safe operation. Actuators shall be protected from overload at all angles of rotation. If required, 1 SPDT auxiliary switch shall be provided having the capability of being adjustable. Actuators must be constructed to meet the requirements for Double Insulation so an electrical ground is not required to meet agency listings. Actuators shall be UL listed and CSA certified, have a 5 year warranty, and be manufactured under ISO 9001 International Quality Control Standards. Actuators shall be as manufactured by Belimo.

Wiring diagrams

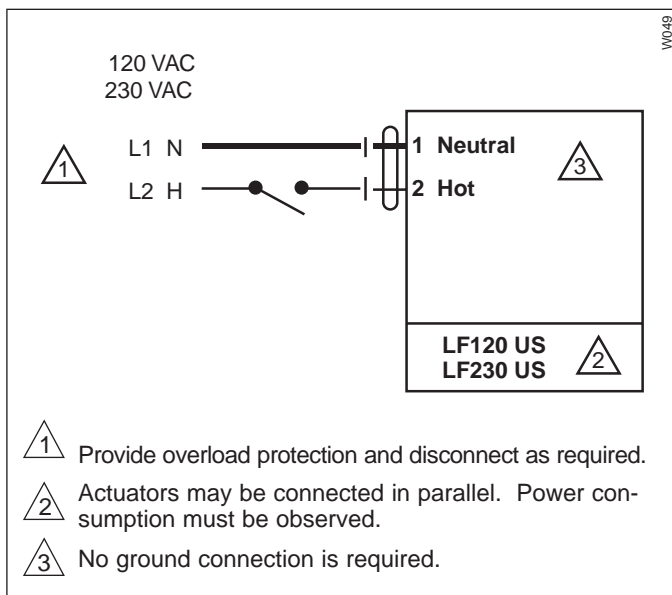

On-off wiring for LF120 US / LF230 US

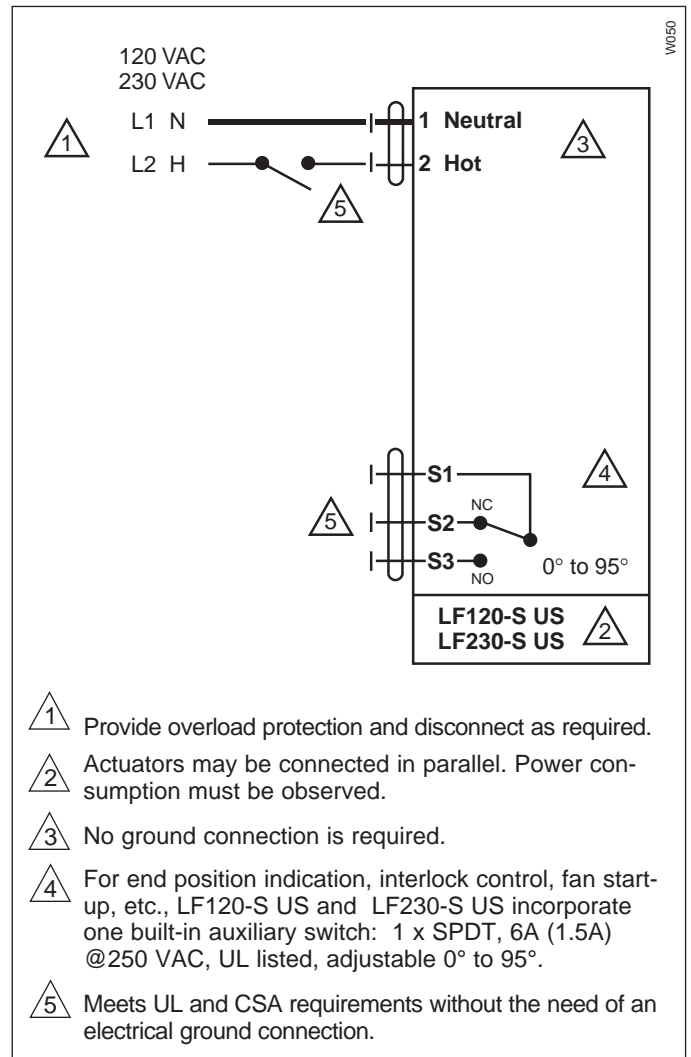

On-off wiring for LF120-S US / LF230-S US