

NM24-SR US

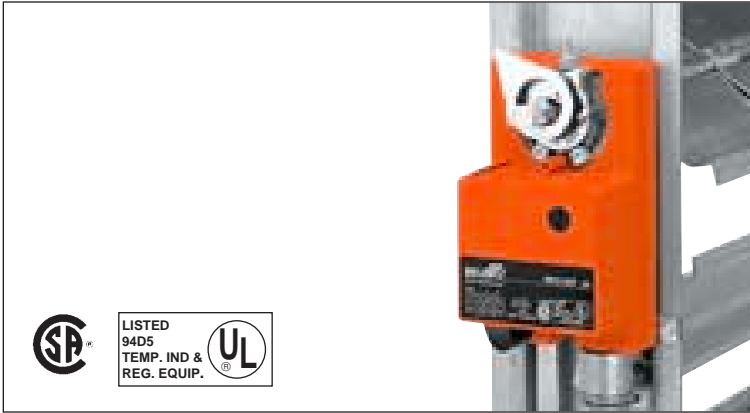

Proportional damper actuator, non-spring return, direct coupled, 24 V, for 2 to 10 VDC and 4 to 20 mA control signal



Torque min. 70 in-lb, for control of air dampers surfaces up to 18 sq. ft.

Application

For proportional modulation of dampers in HVAC systems. Actual actuator sizing should be done in accordance with the damper manufacturer's specifications. The actuator mounts directly to the damper operating shaft with a universal V-bolt clamp assembly.

Operation

The actuator operates in response to a 2 to 10 VDC, 2 to 10 V phasecut or, with the addition of a 500Ω resistor, a 4 to 20 mA control input from an electronic controller or positioner. A 2 to 10 VDC feedback signal is provided for position indication or master-slave applications.

A built-in microprocessor automatically tests for the amount of rotation required to modulate the damper fully closed to fully open. The actuator will self-adjust to run at a consistent running time of 150 seconds, and rescale the input signal so the entire 8 volt control range is used to provide maximum resolution of the control system. The microprocessor will also correct for compression of tight close-off gaskets with age, providing the actuator is not on its mechanical stops. A functional test of the actuator-damper assembly may be done by pressing in the manual override button, this will activate the actuators test mode and cycle the actuator fully open and closed. A 2 to 10 VDC feedback (U) is provided with full 8 volt output range proportional to the operational rotation of the damper.

A digital rotation sensing circuit protects the actuator in a stall anywhere in its 95° working range without the need of limit switches.

Auxiliary switches are easily fastened directly onto the actuator body for signalling and switching functions.

Accessories

- AV 10-18 Damper shaft extension
- SN1,SN2 Auxiliary switches
- ZG-H2 Actuator operator handle
- ZG-NM3 Crank arm adaptor kit for ZG-105
- ZG-NM4 Crank arm adaptor kit
- ZG-NMSA-1 Shaft adaptor for short shafts
- ZG-105 Mounting bracket

Dimensions (All numbers in brackets are metric.)

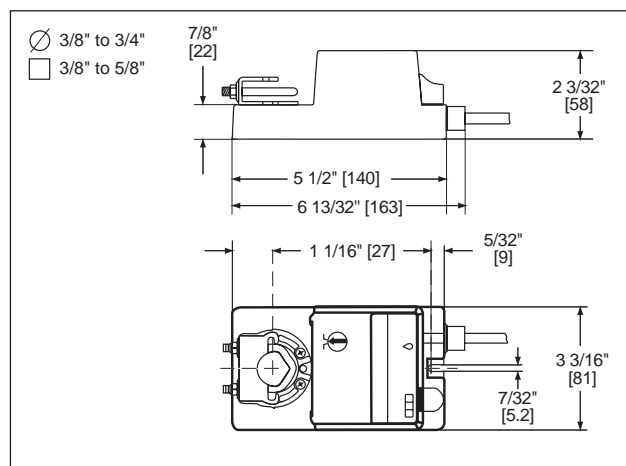

Technical Data	NM24-SR US
Power supply	24 VAC, ± 20%, 50/60 Hz 24 VDC, ±10%
Power consumption	1.3 W
Transformer sizing	3.5 VA (Class 2 power source)
Operating range	2 to 10 VDC, 4 to 20 mA
Input impedance	100kΩ (0.1 mA), 500Ω
Feedback output 'U'	2 to 10 VDC, 0.7 mA max
Electrical connection	3 ft, 18 GA plenum rated (UL CL2P) cable, 1/2" conduit connector
Overload protection	electronic throughout 0 to 95° rotation
Torque (Note 1)	min 70 in-lb (8 Nm)
Damper area (Note 2)	18 sq ft
Direction of rotation	reversible with Switch "L-R" L = CW with an increase in voltage R = CCW with an increase in voltage
Position indication	clip on indicator
Manual override	button on actuator
Angle of rotation	0-95° adjustable stops
Running time (35-95°)	150 seconds independent of max. angle of rotation or torque
Running time (0-35°)	0-150 seconds proportional to max. angle of rotation (Note 3)
Run time stability	± 5%
Humidity	5 to 95% RH, non-condensing
Ambient temperature	-4 to +122° F (-20 to +50° C)
Storage temperature	-40 to +176° F (-40 to +80° C)
Mounting position	not sensitive to position
Housing	NEMA 2
Housing material	UL 94-5V (flammability rating)
Noise level	less than 35 dB (A)
Agency listings	UL 873 listed, CSA C22.2 No.24 certified, CE
Quality standard	ISO 9001
Servicing	maintenance free
Weight	1.8 lbs. (0.8kg.)

Note 1 Minimum torque is produced at minimum voltage, minimum temperature.

Note 2 Damper area is calculated using approximately 4 in-lb/sq ft of damper area. This is an average torque requirement for good quality dampers operating under a 1" WC pressure drop. Check damper specifications for exact torque requirements.

Note 3 The on board microprocessor measures the actuators full stroke on startup. It then adjusts the actuator speed to ensure 150 second run time for 35°-95°. Below 35° stroke, the speed is constant and run time varies with rotation angle.

Proportional damper actuator, non-spring return, direct coupled, 24 V, for 2 to 10 VDC and 4 to 20 mA control signal

Wiring diagrams

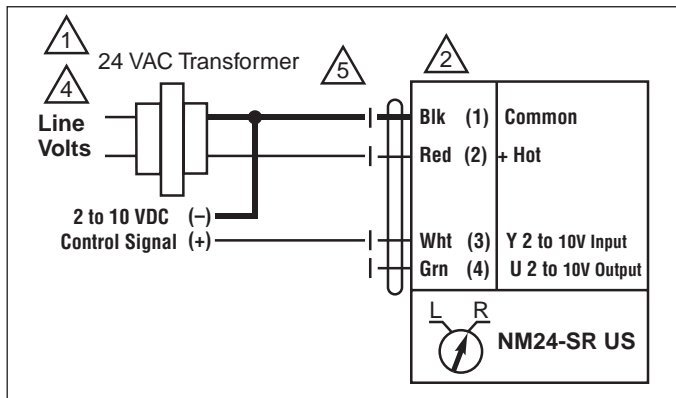

2 to 10 VDC control of NM24-SR US

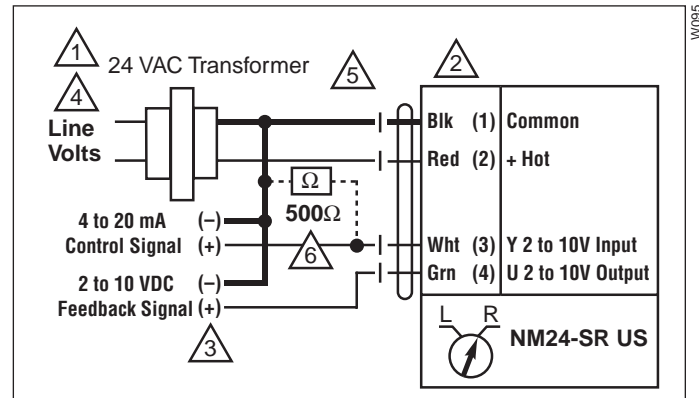

4 to 20 mA control of NM24-SR US with 2 to 10 VDC feedback output

Notes:

- 1 Provide overload protection and disconnect as required.
- 2 Actuators are provided with color coded wires. Wire numbers are provided for reference.
- 3 Connect actuator common (Wire 1) to Negative (-) leg of control circuits only.
- 4 Actuator and controller must have separate transformers.
- 5 May also be powered by 24 VDC.
- 6 The 500Ω resistor converts the 4 to 20 mA control signal to 2 to 10 VDC.

Bulk packaging - NM24-SR.1 US

To have better control of job site inventory and reduce the environmental impact of unnecessary packing material, the NM24-SR us is available in a 24 unit bulk pack.

T-Type bracket

These are included in the single-actuator packages and are available at no extra cost in the bulk packages upon request.

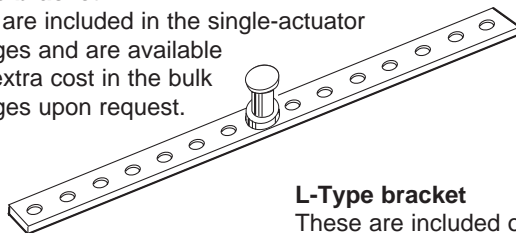

L-Type bracket

These are included only in the bulk-pack actuator packages.

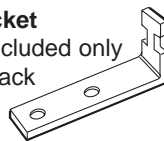

To order use the following part numbers:

Actuator type	Bulk pack number
NM24-SR	NM24-SR.1 (24/box)

Typical Specification:

Control damper actuators shall be electronic direct coupled type which require no crank arm and linkage. Actuators shall be UL and CSA listed, have a 2 year warranty, and be manufactured under ISO 9001 International Quality Control Standards. Actuators shall have reversing switch and gear disengagement button on the cover, and be electronically protected from overload at all angles of rotation. Actuators shall respond to 2 to 10VDC output relative to position regardless of the amount of damper rotation. Actuators shall have brushless DC motor. Run time shall be constant and independent of torque and angular rotation between 35° and 95°. A 2 to 10 VDC feedback signal shall be provided for position indication or master-slave applications. Actuators shall be as manufactured by Belimo.