

## Q624A Solid State Spark Generator

### PRODUCT DATA



- Q624 mounting holes are the same as standard transformers; no adapter plate needed.
- Impervious to humidity up to 95 percent relative humidity.
- Weighs 3 pounds (1.4 kilograms) versus 8-1/2 pounds (3.9 kilograms) for standard transformers.

### SPECIFICATIONS

#### IMPORTANT

*The specifications given in this publication do not include normal manufacturing tolerances. Therefore, this unit may not match the listed specifications exactly. Also, this product is tested and calibrated under closely controlled conditions, and some minor differences in performance can be expected if those conditions are changed.*

#### Models:

Q624A Solid State Spark Generator.  
Q624A1014 with threaded terminal nut high voltage electrode.

#### Electrical Ratings:

Voltage and Frequency: 120 Vac, 50/60 Hz.  
Output Voltage: 10,000 volts.  
Primary VA Rating: 66 VA at 120 Vac.

#### Spark Characteristics:

Firing Rate: 60 sparks per second.  
Voltage, peak-to-peak: 22,000 volts nonsinusoidal.  
Firing cycle peak voltage: 15,000 volts  $\pm$ 500 volts, open circuit.  
Energy Discharge: 200 millijoules per spark.  
Discharge Time: 0.3 milliseconds per spark.  
Power Dissipation: approximately 12 watts per second.

**Maximum High Voltage Lead Length:** 15 ft. (4.6 m)

**Maximum Spark Gap:** 1/4 in. (6 mm).

**Ambient Temperature Range:** -40°F to +125°F (-40°C to +52°C).

**Maximum Ambient Humidity:** 95 percent RH.

**Type of Service:** All types of gas ignition; not recommended for use when igniting oil.

### APPLICATION

The Q624A is a solid state spark generator (transformer) for use on commercial or industrial gas burners.

### FEATURES

- Ignites gas pilots with spark gaps up to 1/4 inch (6 millimeters) in length.
- 15,000 volts peak voltage for reliable lightoff.
- Prevents detection of the ignition spark when properly applied in a flame detection system with the C7027, C7035, or C7044 Minipeeper® or C7061 Dynamic Self-Check Ultraviolet Flame Detector.
- Ignition spark and ultraviolet detector are synchronized by the alternating current supply voltage; spark occurs on one half of the ac cycle and detector operates on the opposite half cycle.
- Recommended for interrupted ignition applications only.
- Mounts in the same space used by conventional ignition transformer.



**Mounting:** Surface.

**Dimensions:** See Fig. 1.

**Weight:** 3 lb. (1.4 kg).

**Approvals:**

Underwriters Laboratories Inc. Component Recognized: File No. MH7453, Guide No. JHYR2; tested and accepted for use in ambient temperatures ranging from -40°F to + 125°F (-40°C to +52°C).

Canadian Standards Association Certified: File No. LR1620.

American Gas Association Design Certified: Certificate No. G-140.401.

**Accessories:**

C7005 Gas Pilot, with ignition electrode.

Q179 Gas Pilot, with ignition electrode.

134666 Insulator; may be used to cover terminal, to prevent contamination, and to give added terminal protection.

32004766-001 24 in. (610 mm) Ignition Cable Assembly.

32004766-002 120 in. (3.05 m) Ignition Cable Assembly.

32004766-003 Ignition Cable (per foot, specify required length).

32004766-004 60 in. (1.52 m) Ignition Cable Assembly. Cable should be rated for 25kV at 482°F (250°C).

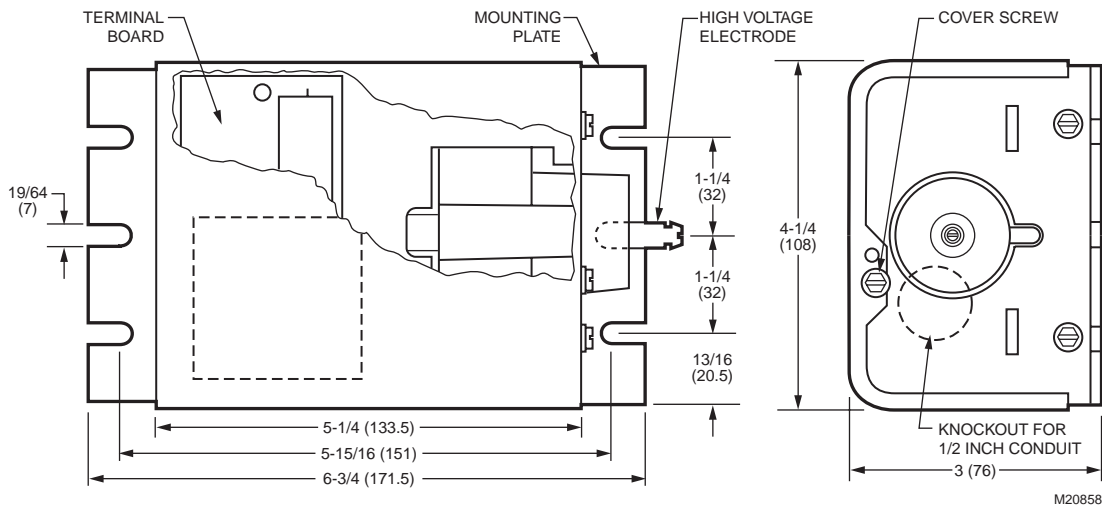

**Fig. 1. Q624A Solid State Spark Generator dimensions in in. (mm).**

**INSTALLATION**

**When Installing This Product...**

1. Read these instructions carefully. Failure to follow them could damage the product or cause a hazardous condition.
2. Check the ratings given in the instructions and on the product to make sure the product is suitable for your application.

3. Installer must be a trained, experienced, flame safeguard control technician.
4. After installation is complete, check out product operation as provided in these instructions.

**ORDERING INFORMATION**

When purchasing replacement and modernization products from your TRADELINE® wholesaler or distributor, refer to the TRADELINE® Catalog or price sheets for complete ordering number.

If you have additional questions, need further information, or would like to comment on our products or services, please write or phone:

1. Your local Honeywell Automation and Control Products Sales Office (check white pages of your phone directory).
2. Honeywell Customer Care  
1885 Douglas Drive North  
Minneapolis, Minnesota 55422-4386

In Canada—Honeywell Limited/Honeywell Limitée, 35 Dynamic Drive, Scarborough, Ontario M1V 4Z9.

International Sales and Service Offices in all principal cities of the world. Manufacturing in Australia, Canada, Finland, France, Germany, Japan, Mexico, Netherlands, Spain, Taiwan, United Kingdom, U.S.A.

## **⚠️ WARNING**

**Electrical Shock Hazard.**  
**Can cause serious injury, death or property damage.**

Disconnect power supply before beginning installation to prevent electrical shock and equipment damage. More than one disconnect may be required.

## **⚠️ CAUTION**

**Equipment Damage Hazard.**  
**Improper grounding can damage equipment.**

Be sure that the mounting chassis of the Q624A is properly grounded at all times, even during bench testing. Otherwise, device may burn out.

## Mounting

The Q624A mounts in the same space required by a standard ignition transformer, using the same mounting holes. It may be mounted in any position.

## WIRING

## **⚠️ WARNING**

**Electrical Shock Hazard.**  
**Can cause serious injury, death or property damage.**

Disconnect power supply before beginning wiring to prevent electrical shock and equipment damage. More than one disconnect may be required.

1. All wiring must comply with applicable local electrical codes, ordinances and regulations.
2. Voltage and frequency of the power supply connected to the Q624A must be 120 Vac, 60 Hz.
3. Be sure the mounting chassis of the Q624A is properly grounded.

### IMPORTANT

*When connecting wires to the screw terminals of the Q624A, wrap the wire 2/3 to 3/4 of the distance around the screw without overlapping (see Fig. 2). Use an appropriately sized screwdriver to securely tighten the screw (at least 12 inch-pounds of torque). Do not use a push-type ratchet screwdriver.*

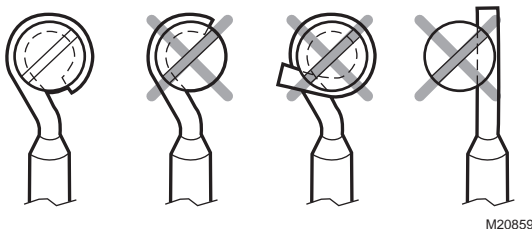

**Fig. 2. Correct and incorrect wire wraps around terminal screws.**

1. Loosen the cover screw (Fig. 1) and remove the cover.
2. Insert two leads (NEC CClass 1) through the 1/2 in. (13 mm) conduit knockout (Fig. 1) and connect them to the screw terminals on the terminal board, and to the terminal strip or wiring subbase of the flame safeguard control (see Table 1 and Fig. 3 or 4).
3. Replace the cover and tighten the cover screw.
4. Connect the high voltage electrode (Fig. 1) to the ignition electrode on the pilot burner, using the appropriate Ignition Cable Assembly or Ignition Cable (see Accessories in the Specifications section).

### IMPORTANT

*The ignition cable should not exceed 15 feet (4.6 meters) in length.*

To ground the Q624 to the burner assembly:

1. Use a No. 16 or No. 18 wire.
2. Attach one end of the wire to the Q624 ignition transformer end (GND).
3. Wrap the wire around the igniter (high tension) lead as shown in Fig. 3. Four or five wraps are sufficient.
4. Connect the other end of the wire to the burner assembly (GND).

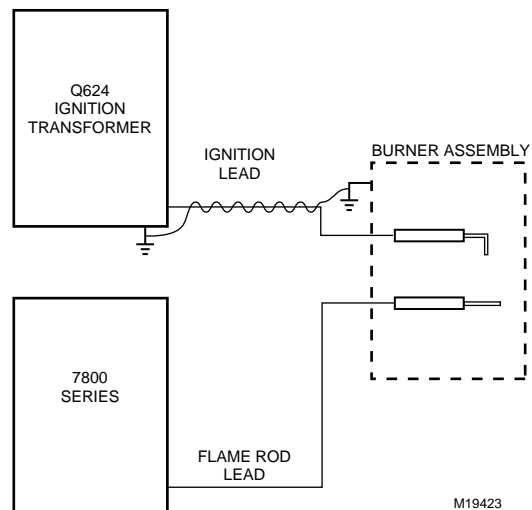

**Fig. 3. Grounding the Q624 to the burner assembly.**

## **⚠️ WARNING**

**Fire or Explosion Hazard.**  
**Can cause serious injury, death or property damage.**

If flame detector and ignition transformer are not properly connected, detector may sense ignition spark, which could open a main gas valve and cause a hazardous condition.

Wiring of terminals T1 and T2 on the Q624A to the proper terminals of the flame safeguard control must be in accordance with Table 1.

Table 1. Wiring Connections.

Flame Safeguard Control Model	Q624A Terminal	Flame Safeguard Control Terminal
RA890G and R4795	T1 T2	4 L2
R4126, R4127, R4140, and BC7000	T1 T2	Appropriate ignition terminal as specified on programmer instruction sheet. L2
R4150	T1 T2	L2 Appropriate ignition terminal as specified on programmer instruction sheet.
RM7800	T1 T2	10 L2

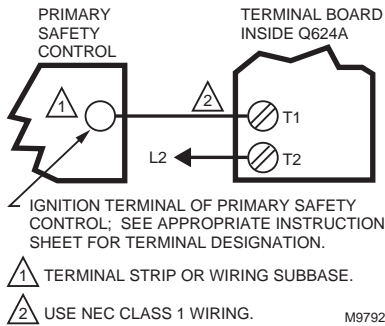

Fig. 4. Q624A connections for RA890G, R4795, R4126, R4127, R4140, BC7000 and 7800 SERIES flame safeguard controls.

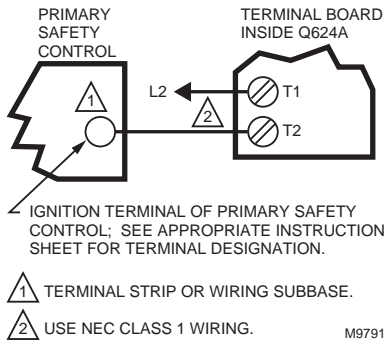

Fig. 5. Q624A connections for R4150 flame safeguard control.

## CHECKOUT

After the Q624A installation and wiring has been completed, make the following checks to ensure that the system is working properly.

### Ignition Spark Response Test

The flame relay should not respond (pull in) to ignition spark. To determine flame detector sensitivity to ignition spark, perform the following steps:

1. Shut off the fuel supply to both pilot and main fuel valves manually.
2. Start system by raising the controller set point or by pressing the Start button.
3. Energize the Q624A Solid State Spark Generator so ignition spark is produced between electrode and ground.
4. Check to be sure that ignition has not occurred (there should be no flame). Repeat steps 1 through 3 above until there is no flame.
5. Check the flame relay on the flame safeguard control. If the relay has not pulled in, the system is operating properly. Continue checkout with the pilot turndown test.
6. If the flame relay pulls in, stop the system, replace the Q624A, and repeat steps 2 through 5.
7. If the flame relay pulls in after replacing the Q624A, stop the system, replace the flame safeguard control, and repeat steps 2 through 5.
8. If the flame relay pulls in after replacing the flame safeguard control, contact the local Honeywell branch office.

### Pilot Turndown Test

Refer to the flame safeguard control instructions for the exact procedure to be used in performing the pilot turndown test.

### Final Checkout

After other checks have been completed, restore the system to normal operation and observe at least one complete cycle of operation to be sure of satisfactory burner operation.

**Honeywell**

#### Automation and Control Solutions

Honeywell International Inc. 1985 Douglas Drive North Golden Valley, MN 55422	Honeywell Limited-Honeywell Limitée 35 Dynamic Drive Scarborough, Ontario M1V 4Z9
---	--