

BARNES[®]

INSTALLATION and OPERATION MANUAL

Submersible Sump Pump

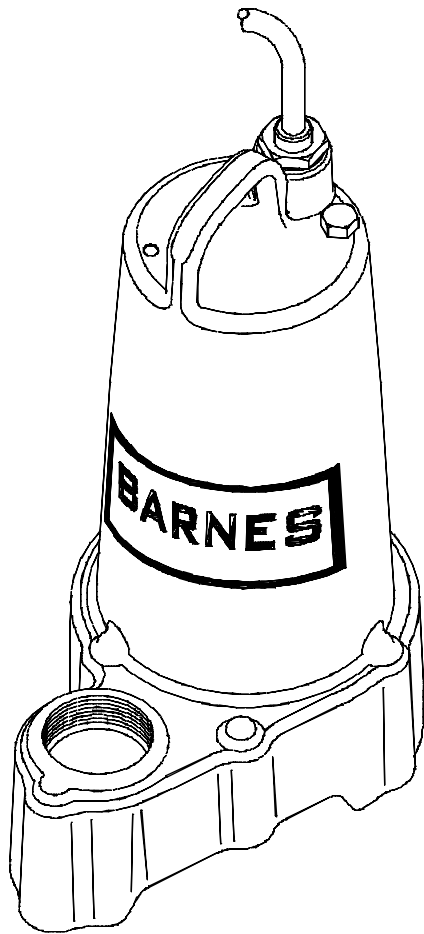

SERIES: SP75X
3/4 HP, 3450 RPM

IMPORTANT: Read all instructions in this manual before operating pump.
As a result of Crane Pumps & Systems, Inc., constant product improvement program, product changes may occur. As such Crane Pumps & Systems, Inc. reserves the right to change product without prior written notification.

CRANE[®]

A Crane Co. Company

PUMPS & SYSTEMS

420 Third Street/P.O. Box 603
Piqua, Ohio 45356-0603
Phone: (937) 778-8947
Fax: (937) 773-7157
www.cranepumps.com

83 West Drive, Brampton
Ontario, Canada L6T 2J6
Phone: (905) 457-6223
Fax: (905) 457-2650

Form No. 115343-Rev. A

SAFETY FIRST!

Please Read This Before Installing Or Operating Pump. This information is provided for **SAFETY and to PREVENT EQUIPMENT PROBLEMS**. To help recognize this information, observe the following symbols:



IMPORTANT! Warns about hazards that can result in personal injury or Indicates factors concerned with assembly, installation, operation, or maintenance which could result in damage to the machine or equipment if ignored.

CAUTION ! Warns about hazards that **can or will cause minor** personal injury or property damage if ignored. Used with symbols below.

WARNING ! Warns about hazards that **can or will cause serious** personal injury, death, or major property damage if ignored. Used with symbols below.



Hazardous fluids can cause fire or explosions, burns or death could result.



Extremely hot - Severe burns can occur on contact.



Toxic Fumes - Breathing can cause nausea, fainting or death.



Hazardous pressure Eruptions or explosions could cause personal injury or property damage



Biohazard can cause serious personal injury.



Hazardous voltage can shock, burn or cause death.



Rotating machinery Amputation or severe laceration can result.



Eye protection required

Only qualified personnel should install, operate and repair pump. Any wiring of pumps should be performed by a qualified electrician.

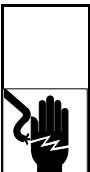

WARNING ! To reduce risk of electrical shock, pumps and control panels must be properly grounded in accordance with the National Electric Code (NEC) or the Canadian Electrical Code (CEC) and all applicable state, province, local codes and ordinances. Improper grounding voids warranty



WARNING ! To reduce risk of electrical shock, always disconnect the pump from the power source before handling or servicing. Lock out power and tag.



WARNING ! Operation against a closed discharge valve will cause premature bearing and seal failure on any pump, and on end suction and self priming pump the heat build may cause the generation of steam with resulting dangerous pressures. It is recommended that a high case temperature switch or pressure relief valve be installed on the pump body.



CAUTION ! Never operate a pump with a plug-in type power cord without a ground fault circuit interrupter.



CAUTION ! Pumps build up heat and pressure during operation-allow time for pumps to cool before handling or servicing.



WARNING ! Do not pump hazardous materials (flammable, caustic, etc.) unless the pump is specifically designed and designated to handle them.



CAUTION ! Do not block or restrict discharge hose, as discharge hose may whip under pressure.



WARNING ! Do not wear loose clothing that may become entangled in moving parts.



WARNING ! Keep clear of suction and discharge openings. **DO NOT** insert fingers in pump with power connected.



Make sure lifting handles are securely fastened each time before lifting. **DO NOT** operate pump without safety devices in place. Always replace safety devices that have been removed during service or repair. Secure the pump in its operating position so it can not tip over, fall or slide.

DO NOT exceed manufacturers recommendation for maximum performance, as this could cause the motor to overheat.

DO NOT remove cord and strain relief. **DO NOT** connect conduit to pump.



WARNING ! Cable should be protected at all times to avoid punctures, cut, bruises and abrasions. Inspect frequently. Never handle connected power cords with wet hands.

WARNING ! To reduce risk of electrical shock, all wiring and junction connections should be made per the NEC or CEC and applicable state or province and local codes. Requirements may vary depending on usage and location.

WARNING ! Submersible Pumps are not approved for use in swimming pools, recreational water installations decorative fountains or any installation where human contact with the pumped fluid is common.



WARNING ! Products returned must be cleaned, sanitized, or decontaminated as necessary prior to shipment, to insure that employees will not be exposed to health hazards in handling said material. All Applicable Laws And Regulations Shall Apply.

Bronze/brass and bronze/brass fitted pumps may contain lead levels higher than considered safe for potable water systems. Various government agencies have determined that leaded copper alloys should not be used in potable water applications. For non-leaded copper alloy materials of construction, please contact factory.



BARNES® Pumps, Inc. is not responsible for losses, injury, or death resulting from a failure to observe these safety precautions, misuse or abuse of pumps or equipment.

SECTION: A- PUMP SPECIFICATIONS

DISCHARGE: 1-1/2" N.P.T. Female, Vertical
LIQUID TEMPERATURE: 104°F (40°C) Continuous
MOTOR HOUSING: Cast Iron
PUMP STRAINER: Thermoplastic
IMPELLER: *Design:* 10 Vane Vortex, with Pump Out Vanes
On Back Side. Balanced, ISO G6.3
Material: Cast Iron
SHAFT: Stainless Steel
O-RINGS: Buna-N
HARDWARE: 300 Series Stainless Steel
PAINT: Air Dry Enamel
CABLE ENTRY: 20Ft (6M) Cord with Plug and Pressure
Grommet for Sealing and Strain Relief
SEAL: *Design:* Single Mechanical
Material: Silicon Carbide/Silicon Carbide/Buna-N
Hardware - 300 Series Stainless
UPPER BEARING: Single Row, Ball, Oil Lubricated
LOWER BEARING: Single Row, Ball, Oil Lubricated

MOTOR: *Design:* Oil-Filled.
Insulation: Class B.
ELECTRICAL: 120 Volt, 1 Phase, 60Hz, 9.8 FLA
NEMA Start Code - H
WINDING RESISTANCE:
Main: 3.5 Ω
Start: 4.3 Ω
SINGLE PHASE: Permanent Split Capacitor (PSC). Includes
Thermal Overload Protection in Motor
FLOAT: SP75X None
SP75AX Wide Angle, Mechanical, 20 Ft (6M) Cable.
SP75VFX Vertical Float, PVC, Snap Action,
20 Ft (6M) Cable.
MINIMUM SUMP DIA:
SP75AX: 18" (457mm)
SP75, SP75VF: 12" (305mm)

inches
(mm)

Model: SP75X

**Model: SP75AX
Mech. Wide Angle Float**

**Model: SP75VFX
Vertical Float**

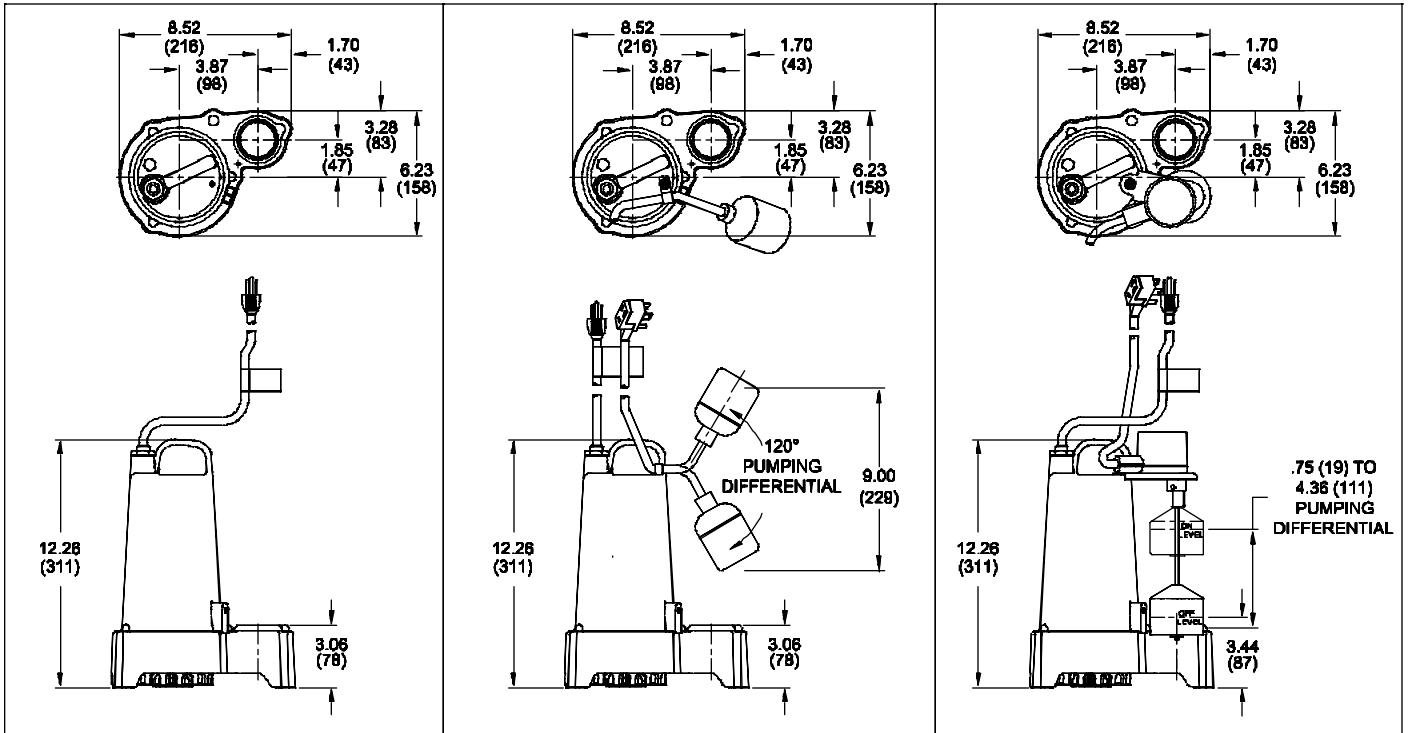

SECTION B: GENERAL INFORMATION

B-1) To the Purchaser:

Congratulations! You are the owner of one of the finest pumps on the market today. Barnes® Pumps are products engineered and manufactured of high quality components. Over one hundred years of pump building experience along with a continuing quality assurance program combine to produce a pump which will stand up to the toughest applications.

Check local codes and requirements before installation. Servicing should be performed by knowledgeable pump service contractors or authorized service stations.

The pump is packaged ready for installation and no connections or adjustments are necessary except for attaching discharge piping and plugging in service cord.

B-2) Receiving

Upon receiving the pump, it should be inspected for damage or shortages. If damage has occurred, file a claim immediately with the company that delivered the pump. If the manual is removed from the crating, do not lose or misplace.

B-3) Storage:

Short Term- Barnes Pumps are manufactured for efficient performance following long inoperative periods in storage. For best results, pumps can be retained in storage, as factory assembled, in a dry atmosphere with constant temperatures for up to six (6) months.

Long Term- Any length of time exceeding six (6) months, but not more than twenty four (24) months. The units should be stored in a temperature controlled area, a roofed over walled enclosure that provides protection from the elements (rain, snow, wind blown dust, etc.), and whose temperature can be maintained between +40 deg. F and +120 deg. F. Pump should be stored in its original shipping container and before initial start up, rotate impeller by hand to assure seal and impeller rotate freely.

B-4) SERVICE CENTERS:

For the location of the nearest Barnes Pumps Service Center, check your catalog, your Barnes Pumps, Inc. representative or Barnes Pumps, Inc. Service Department in Piqua, Ohio, telephone (937) 778-8947 or Crane Pumps & Systems Canada, Inc., Bramton, Ontario, (905) 457-6223.

SECTION C: INSTALLATION

C-1) Location:

These pumping units are self-contained and are recommended for use in a sump or basin. This pump is designed to pump rain water or light effluent, nonexplosive and noncorrosive liquids and shall **NOT** be installed in locations classified as hazardous in accordance with the National Electrical Code (NEC), ANSI/NFPA 70 or the Canadian Electrical Code (CEC). The sump or basin shall be vented in accordance with local plumbing codes. Provide proper sump diameter of approx. 18" (457mm) minimum and depth of approx. 20" (508mm) minimum to allow the pump and switch to operate without restriction. The float switch should not come in contact with side or bottom of sump. Make sure sump is free of string, cloth, nails, gravel, etc. before installing pump. Never install the pump in a trench, ditch, or hole with a dirt bottom where the suction will become plugged.

C-1.1) Submergence:

The minimum sump liquid level should never be less than 4 inches (102mm) above the pump bottom.

C-2) Discharge:

Discharge piping should be as short as possible. The installation of a check valve in the discharge piping is recommended for each pump being used. The check valve is used to prevent backflow into the sump. Excessive backflow can cause flooding and/or damage to the pump.

C-3) Liquid Level Controls

Figure 2 shows a typical installation for a submersible pump using a piggy-back wide angle level control mounted to the pump.

TYPICAL INSTALLATION WITH PIGGY-BACK WIDE ANGLE LEVEL CONTROL

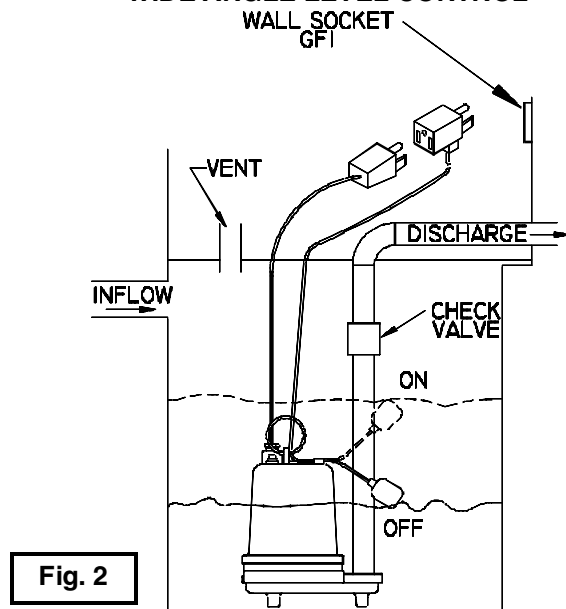

Fig. 2

General Comments:

- 1) Never work in the sump with the power on.
- 2) Level controls are factory set. Be certain that the level control cannot hang up or foul in it's swing. Also, make certain the pump impeller is still submerged when the level control is in the 'off' mode.
- 3) Plug the pump plug into a GFI receptacle. One cycle of operation should be observed, so that any potential problems can be corrected.

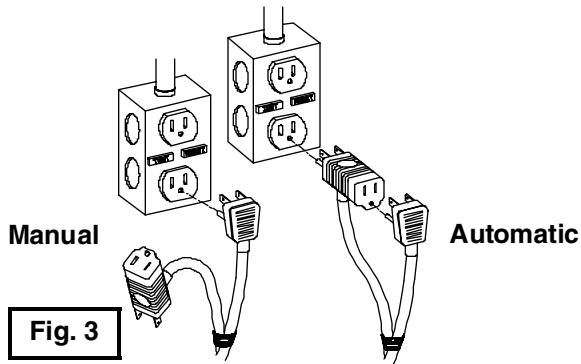

Figure 3 shows a typical connection for pumps with the piggy-back plug, for manual and automatic operations.

- Automatic- Plug float cord into GFI outlet, then plug pump cord into float cord.
- Manual- Plug pump cord directly into GFI outlet.

IMPORTANT! - When Installing Vertical Float Pumps, Check To Be Sure Float Is Not Hung Up On Top Of Volute Housing.

C-4) Electrical Connections:

C-4.1) Power Cable:

The cord assembly mounted to the pump must not be modified in any way. This pump comes complete with a 3 wire cord and 3 prong grounded plug that must be connected into a 3 wire grounded Ground Fault receptacle. **DO NOT** remove ground pin from electrical plug. It is **NOT** recommended to use an extension cord with these pumps. **DO NOT USE THE POWER CABLE TO LIFT PUMP.**

C-4.2) Overload Protection:

Automatic thermal overload protects the sealed-in-oil motor. Running dry may overheat the motor and trip the overload. The type of in-winding overload protector used is referred to as an inherent overheating protector and operates on the combined effect of temperature and current. This means that the overload protector will trip out and shut the pump off if the windings become too hot, or the load current passing through them becomes too high. It will then automatically reset and start the pump up after the motor cools to a safe temperature. In the event of an overload, the source of this condition should be determined and rectified immediately. **DO NOT LET THE PUMP CYCLE OR RUN IF AN OVERLOAD CONDITION OCCURS !**

SECTION D: SERVICE AND REPAIR

WARNING ! - DO NOT overfill oil. Overfilling of motor housing with oil can create excessive and dangerous hydraulic pressure which can destroy the pump and create a hazard. Overfilling oil voids warranty.

D-1) Bottom Plate:

Remove screws, and remove bottom plate from volute and remove volute. Clean and examine impeller. If impeller vanes are clogged, or it is excessively worn or broken, the impeller should be replaced.

D-2) Impeller:

After removing the bottom plate the impeller, may be removed by turning impeller counterclockwise to remove from shaft. When reassembling the impeller, turn the impeller clockwise until it bottoms against shaft. Replace volute, bottom plate, and screws.

COOLING OIL - Dielectric	
SUPPLIER	GRADE
BP	Enerpar SE100
Conoco	Pale Paraffin 22
Mobile	D.T.E. Oil Light
G & G Oil	Circulating 22
Imperial Oil	Voltesso-35
Shell Canada	Transformer -10
Texaco	Diala-Oil-AX
Woco	Premium-100

SECTION: E WARRANTY REPAIR

E-1) INFORMATION NEEDED:

ALWAYS furnish the following information:

1. Pump Part Number
2. Pump model number
3. Pump date code

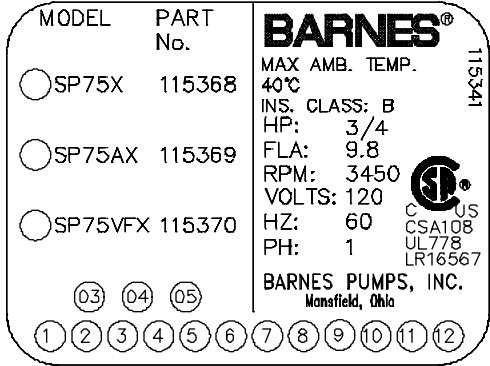

E-2 MODEL NUMBER:

This designation consists of numbers and letters which represents the horsepower, motor phase and voltage, and pump design. This number is used for ordering and obtaining information.

E-3 DATE CODE:

The Date Code consists of two numbers which are punched holes in the nameplate. This specifies the month and year which indicates the date the unit was built.

SERVICE PARTS AVAILABLE - LEVEL CONTROLS

- | | |
|----------|------------------------------------|
| 113647 | Vertical Float 10 Ft. Piggy Back |
| 113647A | Vertical Float 20 Ft. Piggy Back |
| 106929 | Mech. Wide Angle 10 Ft. Piggy Back |
| 101758XA | Mech. Wide Angle 20 Ft. Piggy Back |

Pumps Sold as Complete Units Only, Except for Above Listed Level Controls

E-2 PART NUMBER:

The part number consists of a six (6) digit number, which appears in the catalog. A one or two letter suffix may follow this number to designate the design configuration. This number is used for ordering and obtaining information.

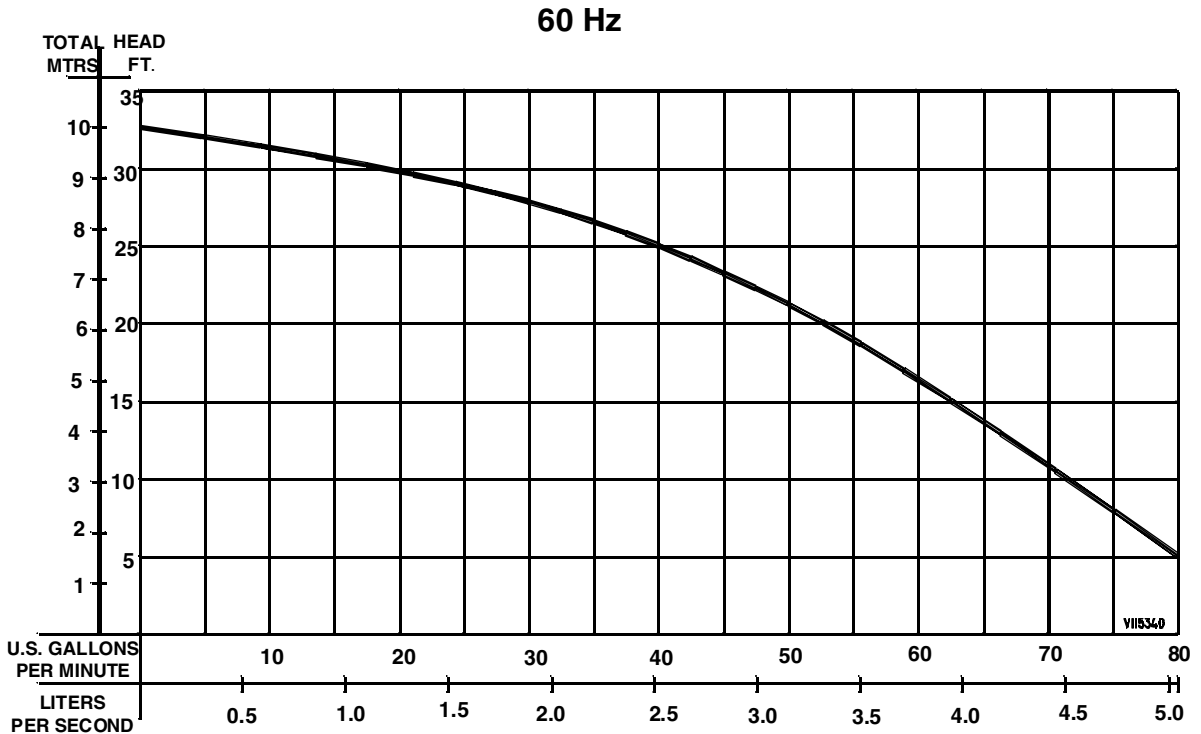

Testing is performed with water, specific gravity of 1.0 @ 68° F (20°C), other fluids may vary performance.

TROUBLESHOOTING

CAUTION ! Always disconnect the pump from the electrical power source before handling.
 If the system fails to operate properly, carefully read instructions and perform maintenance recommendations.
 If operating problems persist, the following chart may be of assistance in identifying and correcting them:
MATCH "CAUSE" NUMBER WITH CORRELATING "CORRECTION" NUMBER.

NOTE: Not all problems and correction will apply to each pump model.

PROBLEM	CAUSE	CORRECTION
Pump will not run.	1. Poor electrical connection, blown fuse, tripped breaker or other interruption of power; improper power supply. 2. Motor or switch inoperative (to isolate cause, go to manual operation of pump). 2a. Float movement restricted. 2b. Switch will not activate pump or is defective. 2c. Defective motor. 3. Insufficient liquid level.	1. Check all electrical connections for security. Have electrician measure current in motor leads, if current is within $\pm 20\%$ of locked rotor Amps, impeller is probably locked. If current is 0, overload may be tripped. Remove power, allow pump to cool, then recheck current. 2a. Reposition pump or clean basin as required to provide adequate clearance for float. 2b. Disconnect level control. Set ohmmeter for a low range, such as 100 ohms full scale and connect to level control leads. Actuate level control manually and check to see that ohmmeter shows zero ohms for closed switch and full scale for open switch. (Float Switch). 2c. Check winding insulation (Megger Test) and winding resistance. If check is out side of range, dry and recheck. If still defective, replace per service instructions. 3. Make sure liquid level is at least equal to suggested turn-on point.
Pump will not turn off.	2a. Float movement restricted. 2b. Switch will not activate pump or is defective. 4. Excessive inflow or pump not properly sized for application. 9. Pump may be airlocked. 14. Switch is in "HAND" position.	4. Recheck all sizing calculations to determine proper pump size. 5. Check discharge line for restrictions, including ice if line passes through or into cold areas. 6. Remove and examine check valve for proper installation and freedom of operation. 7. Open valve. 8. Check impeller for freedom of operation, security and condition. Clean impeller cavity and inlet of any obstruction. 9. Loosen union slightly to allow trapped air to escape. Verify that turn-off level of switch is set so that impeller cavity is always flooded. Clean vent hole.
Pump hums but doesn't run.	1. Incorrect voltage. 8. Impeller jammed or loose on shaft, worn or damaged, impeller cavity or inlet plugged.	10. Check rotation. If power supply is three phase, reverse any two of three power supply leads to ensure proper impeller rotation. 11. Repair fixtures as required to eliminate leakage. 12. Check pump temperature limits & fluid temperature.
Pump delivers insufficient capacity.	1. Incorrect voltage. 4. Excessive inflow or pump not properly sized for application. 5. Discharge restricted. 6. Check valve stuck closed or installed backwards. 7. Shut-off valve closed. 8. Impeller jammed or loose on shaft, worn or damaged, impeller cavity or inlet plugged. 9. Pump may be airlocked. 10. Pump running backwards.	13. Replace portion of discharge pipe with flexible connector. 14. Turn to automatic position. 15. Check for leaks around basin inlet and outlets.
Pump cycles too frequently or runs periodically when fixtures are not in use.	6. Check valve stuck closed or installed backwards. 11. Fixtures are leaking. 15. Ground water entering basin.	
Pump shuts off and turns on independent of switch. (trips thermal overload protector). CAUTION! Pump may start unexpectedly. Disconnect power supply. NOTE: Some pumps DO NOT have thermal overload protection on the motor. Check pump specifications to determine.	1. Incorrect voltage. 4. Excessive inflow or pump not properly sized for application. 8. Impeller jammed, loose on shaft, worn or damaged, impeller cavity or inlet plugged. 12. Excessive water temperature (internal protection only).	
Pump operates noisily or vibrates excessively.	2c. Worn bearings, motor shaft bent. 8. Debris in impeller cavity or broken impeller. 10. Pump running backwards. 13. Piping attachments to building structure too rigid or too loose.	

IMPORTANT ! WARRANTY REGISTRATION

**Your product is covered by the enclosed Warranty.
Complete the Warranty Registration Form and returned to
Crane Pumps & Systems, Inc. Warranty Service Group**

**IMPORTANT! If you have a claim under the provision of the warranty,
contact your local Crane Pumps & Systems, Inc. Distributor.**

RETURNED GOODS

**RETURN OF MERCHANDISE REQUIRES A "RETURNED GOODS AUTHORIZATION".
CONTACT YOUR LOCAL CRANE PUMPS & SYSTEMS, INC. DISTRIBUTOR.**



**Products Returned Must Be Cleaned, Sanitized,
Or Decontaminated As Necessary Prior To Shipment,
To Insure That Employees Will Not Be Exposed To Health
Hazards In Handling Said Material. All Applicable Laws
And Regulations Shall Apply.**

Limited Warranty

We warrant to our immediate customer and to the ultimate consumer that products of our manufacture will be free of defects in material and workmanship under normal use and service for the following time periods, when installed and maintained in accordance with our instructions. Pump Products: One (1) year from date of installation or (24) twenty-four months from date of shipment, whichever occurs first. Cleaning Products: Twelve (12) months from date of installation or eighteen (18) months from date of shipment, whichever occurs first. As used herein, "the ultimate consumer" is defined as the purchaser who first uses the product after its initial installation or, in the case of product designed for non permanent installation, the first owner who used the product. It is the purchaser's or any sub-vendee's obligation to make known to the ultimate consumer the terms and conditions of this warranty. This warranty gives you specific legal rights, and there may also be other rights which vary from state to state. In the event the product is covered by the Federal Consumer Product Warranties Law (1) the duration of any implied warranties associated with the product by virtue of said law is limited to the same duration as stated herein, (2) this warranty is a LIMITED WARRANTY, and (3) no claims of any nature whatsoever shall be made against us, until the ultimate consumer, his successor, or assigns, notifies us in writing of the defect, and delivers the product and/or defective part(s) freight prepaid to our factory or nearest authorized service station. Some states do not allow limitations on how long an implied warranty lasts, so the above limitation may not apply. **THE SOLE AND EXCLUSIVE REMEDY FOR BREACH OF ANY AND ALL WARRANTIES WITH RESPECT TO ANY PRODUCT SHALL BE TO REPLACE OR REPAIR AT OUR ELECTION, F.O.B. POINT OF MANUFACTURE OR AUTHORIZED REPAIR STATION, SUCH PRODUCTS AND/OR PARTS AS PROVEN DEFECTIVE. THERE SHALL BE NO FURTHER LIABILITY, WHETHER BASED ON WARRANTY, NEGLIGENCE OR OTHERWISE.** Unless expressly stated otherwise, guarantees in the nature of performance specifications furnished in addition to the foregoing material and workmanship warranties on a product manufactured by us, if any, are subject to laboratory tests corrected for field performance. Any additional guarantees, in the nature of performance specifications must be in writing and such writing must be signed by our authorized representative. Due to inaccuracies in field testing if a conflict arises between the results of field testing conducted by or for user, and laboratory tests corrected for field performance, the latter shall control. Components or accessories supplied by us but manufactured by others are warranted only to the extent of and by the terms and conditions of the original manufacturer's warranty. **RECOMMENDATIONS FOR SPECIAL APPLICATIONS OR THOSE RESULTING FROM SYSTEMS ANALYSES AND EVALUATIONS WE CONDUCT WILL BE BASED ON OUR BEST AVAILABLE EXPERIENCE AND PUBLISHED INDUSTRY INFORMATION. SUCH RECOMMENDATIONS DO NOT CONSTITUTE A WARRANTY OF SATISFACTORY PERFORMANCE AND NO SUCH WARRANTY IS GIVEN.**

This warranty shall not apply when damage is caused by (a) improper installation, (b) improper voltage (c) lightning (d) sand or other abrasive material (e) scale or corrosion build-up due to excessive chemical content. Any modification of the original equipment will also void the warranty. We will not be responsible for loss, damage or labor cost due to interruption of service caused by defective parts. Neither will we accept charges incurred by others without our prior written approval.

This warranty is void if our inspection reveals the product was used in a manner inconsistent with normal industry practice and/or our specific recommendations. The purchaser is responsible for communication of all necessary information regarding the application and use of the product. **UNDER NO CIRCUMSTANCES WILL WE BE RESPONSIBLE FOR ANY OTHER DIRECT OR CONSEQUENTIAL DAMAGES, INCLUDING BUT NOT LIMITED TO LOST PROFITS, LOST INCOME, LABOR CHARGES, DELAYS IN PRODUCTION, IDLE PRODUCTION, WHICH DAMAGES ARE CAUSED BY ANY DEFECTS IN MATERIAL AND/OR WORKMANSHIP AND/OR DAMAGE OR DELAYS IN SHIPMENT. THIS WARRANTY IS EXPRESSLY IN LIEU OF ANY OTHER EXPRESS OR IMPLIED WARRANTY, INCLUDING ANY WARRANTY OF MERCHANTABILITY OR FITNESS FOR A PARTICULAR PURPOSE.**

No rights extended under this warranty shall be assigned to any other person, whether by operation of law or otherwise, without our prior written approval.

**IMPORTANT !
WARRANTY REGISTRATION**

**Your product is covered by the enclosed Warranty.
Complete the Warranty Registration Form and returned to
Crane Pumps & Systems, Inc. Warranty Service Group**

**IMPORTANT! If you have a claim under the provision of the warranty,
contact your local Crane Pumps & Systems, Inc. Distributor.**

FOLD HERE

**** IMPORTANT ! ****

WARRANTY REGISTRATION

CUSTOMER'S NAME _____ DATE INSTALLED _____

ADDRESS _____

CITY _____ STATE _____ ZIP _____

PHONE # _____ FAX # _____

DEALER'S NAME _____

CITY _____ STATE _____ ZIP _____

MODEL NO. _____ SERIAL NO. _____

PART NO. _____ BRAND: _____

FOLD HERE AND TAPE, DO NOT STAPLE

PLACE
STAMP
HERE

**CRANE PUMPS & SYSTEMS, INC.
WARRANTY SERVICE GROUP
420 THIRD STREET
P.O. BOX 603
PIQUA, OHIO
45356-0603 - U.S.A.**