

**GAS APPLIANCE REGULATORS**

BY

**MAXITROL<sup>®</sup>**  **company****R400, R500, R600 &  
R400S, R500S & R600S****R&RS  
series****MAXIMUM INLET PRESSURES:**

CSA Certified

All R &amp; RS models.....1/2 psi (34 mbar)

Maxitrol Tested

R400, R500, &amp; R600.....1.0 psi (69 mbar)

R400S, R500S &amp; R600S.....5.0 psi (345 mbar)

**EMERGENCY EXPOSURE LIMITS:**

R400, R500, R600.....2.0 psi (138 mbar)

R400S, R500S, &amp; R600S.....12.5 psi (862 mbar)

**AMBIENT TEMPERATURE LIMITS:**

R400, R500, R600,

R400S, R500S, &amp; R600S.....-40° to 205°F (-40° to 96° C)

**VENTING**.....1/8" NPT**GASES:** Natural, manufactured, mixed, liquified petroleum or LP gas-air mixutre.**MOUNTING:** Suitable for multiple-poise mounting-mount with flow direction as marked on bottom casting.**NOTE:** All Maxitrol appliance regulators should be installed and operated in accordance with Maxitrol's "Safety Warning" Bulletin.

**These regulators are not suitable for dead-end lock-up service. They are capable of controlling pressure at very low flows such as standing pilots, but should not be used as a line gas pressure regulator for appliances equipped with electronic ignition unless automatic control valve can open against line pressure.**

The R & RS series is intended for use with both main burner and pilot load applications. The double diaphragm balanced valve design makes it possible to build a regulator physically small in size yet having good capacity characteristics. They are able to maintain steady outlet pressure control with widely varying inlet pressures. The high quality molded balancing diaphragm eliminates the inlet pressure effect acting on the valve.

**balanced valve  
design**

The housings are rugged aluminum die castings. All internal components are carefully selected and corrosion resistant. The diaphragms are of high quality supported synthetic rubber components having excellent low temperature performance. The RS models incorporate a resilient chemically bonded synthetic rubber ring on the valve member. The soft seating insures satisfactory pilot control at inlet pressures up to 5 psi.

These regulators are ideally suited for use with infrared heaters and pilot lines on large industrial heaters and boilers. They may also be used in residential applications. Because of their high pressure drop capacities, both the R & RS models will operate satisfactorily on domestic as well as elevated pressures. Appliances may be shipped to any area having supply pressures from 7.0" w.c. to 5 psi without changing regulators. They find wide applications on commercial and industrial equipment, especially where precise outlet pressure accuracy is required.

Any of the R models can be furnished for zero governor applications.

# Specifications

## REGULATORS FOR ZERO GOVERNOR APPLICATIONS:

R400Z, R500Z & R600Z – These regulators are equipped with a counter spring beneath the valve for zero governor use in the normal upright position.

A maximum inlet pressure of 1 psi is recommended, and outlet pressure may be adjusted from -1.0" to +1.5" w.c.

At any given flow rate the regulation accuracy is +/- 0.2" w.c. over varying inlet pressures up to 1 psi.

See Bulletin MS 2043

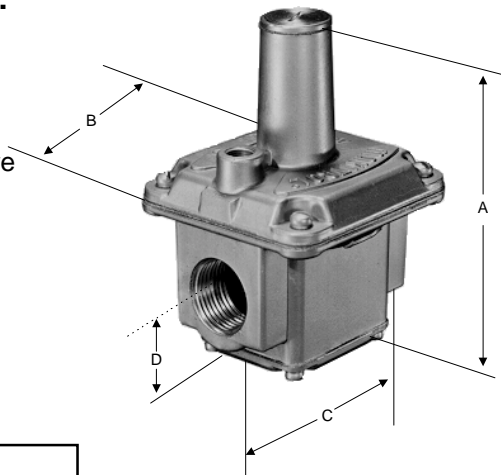

## DIMENSIONS – in inches (millimeters)

Swing Model Number	Radius	Call-Outs			
		A	B	C	D
R400 & R400S	2.38 (60)	3.25 (83)	2 (51)	2 (51)	.94 (24)
R500 & R500S	3.56 (90)	4.69 (119)	3.13 (79)	3 (76)	1.19 (30)
R600 & R600S	4.32 (109.7)	5.68 (144.3)	3.88 (98.3)	4.03 (102.4)	1.46 (37.1)

## SPRING SELECTION CHART – in inches (mbar)

Model Number with Standard Spring		Other Springs Available							
R400 & R400S	3 to 6	1 - 3.5 (2.5 - 9)	2 - 5 (5 - 12.5)	3 - 8 (7.5 - 20)	—	4 - 12 (10 - 30)	5 - 12 (12.5 - 30)	10 - 22 (25 - 55)	—
R500 & R500S	3 to 6	1 - 3.5 (2.5 - 9)	2 - 5 (5 - 12.5)	3 - 8 (7.5 - 20)	4 - 8 (10 - 20)	4 - 12 (10 - 30)	5 - 12 (12.5 - 30)	10 - 22 (25 - 55)	—
R600 & R600S	3 to 6	2 - 5 (5 - 12.5)	2 - 5 (5 - 12.5)	3 - 8 (7.5 - 20)	4 - 8 (10 - 20)	4 - 12 (10 - 30)	5 - 12 (12.5 - 30)	10 - 22 (25 - 55)	15 - 30 (38 - 75)

## CAPACITIES — expressed in CFH (m<sup>3</sup>/h) @ 0.64 sp gr gas

Model Number and Pipe Size		Pressure Drop inches w.c. (mbar)										
		0.2 (.50)	0.4 (1.00)	0.6 (1.5)	0.8 (2.0)	1.0 (2.5)	1.5 (3.7)	2.0 (5.0)	2.5 (6.2)	3.0 (7.5)	3.5 (8.7)	4.0 (10.0)
R400 & R400S	3/8 x 3/8	77 (2.16)	110 (3.08)	134 (3.75)	155 (4.34)	174 (4.87)	212 (5.94)	245 (6.86)	274 (7.67)	—	—	—
	1/2 x 1/2	86 (2.41)	121 (3.39)	148 (4.14)	172 (4.82)	192 (5.38)	235 (6.58)	271 (7.59)	303 (8.48)	—	—	—
R500 & R500S	1/2 x 1/2	163 (4.56)	231 (6.47)	283 (7.92)	327 (9.16)	366 (10.25)	447 (12.52)	516 (14.55)	577 (16.16)	635 (17.78)	685 (19.18)	730 (20.44)
	3/4 x 3/4	196 (5.49)	277 (7.76)	340 (9.52)	392 (10.97)	438 (12.26)	537 (15.04)	620 (17.36)	693 (19.40)	760 (21.28)	820 (22.96)	876 (24.53)
R600 & R600S	3/4 x 3/4	298 (8.34)	421 (11.79)	516 (14.45)	595 (16.66)	666 (18.65)	816 (22.85)	942 (26.38)	1,054 (29.51)	1,150 (32.20)	1,245 (34.86)	1,335 (37.38)
	1 x 1	330 (9.24)	468 (13.10)	572 (16.02)	661 (18.21)	739 (20.69)	906 (25.37)	1,046 (29.29)	1,169 (32.73)	1,280 (35.84)	1,380 (38.64)	1,480 (41.44)

A copyrighted publication of

**MAXITROL**®  **company**

[www.maxitrol.com](http://www.maxitrol.com)

Maxitrol Company  
23555 Telegraph Rd., P.O. Box 2230  
Southfield, MI 48037-2230 U.S.A.



European Representatives  
Warnstedter Strasse 3 06502 Thale, Germany  
49.3947.400.0 • Fax 49.3947.400.200  
Industriestrasse 1 48308 Senden, Germany  
49.2597.9632.0 • Fax 49.2597.9632.99

